

wilo

WILO EMUport, a dugulásmentes átemelő

Katus Viktor 2019

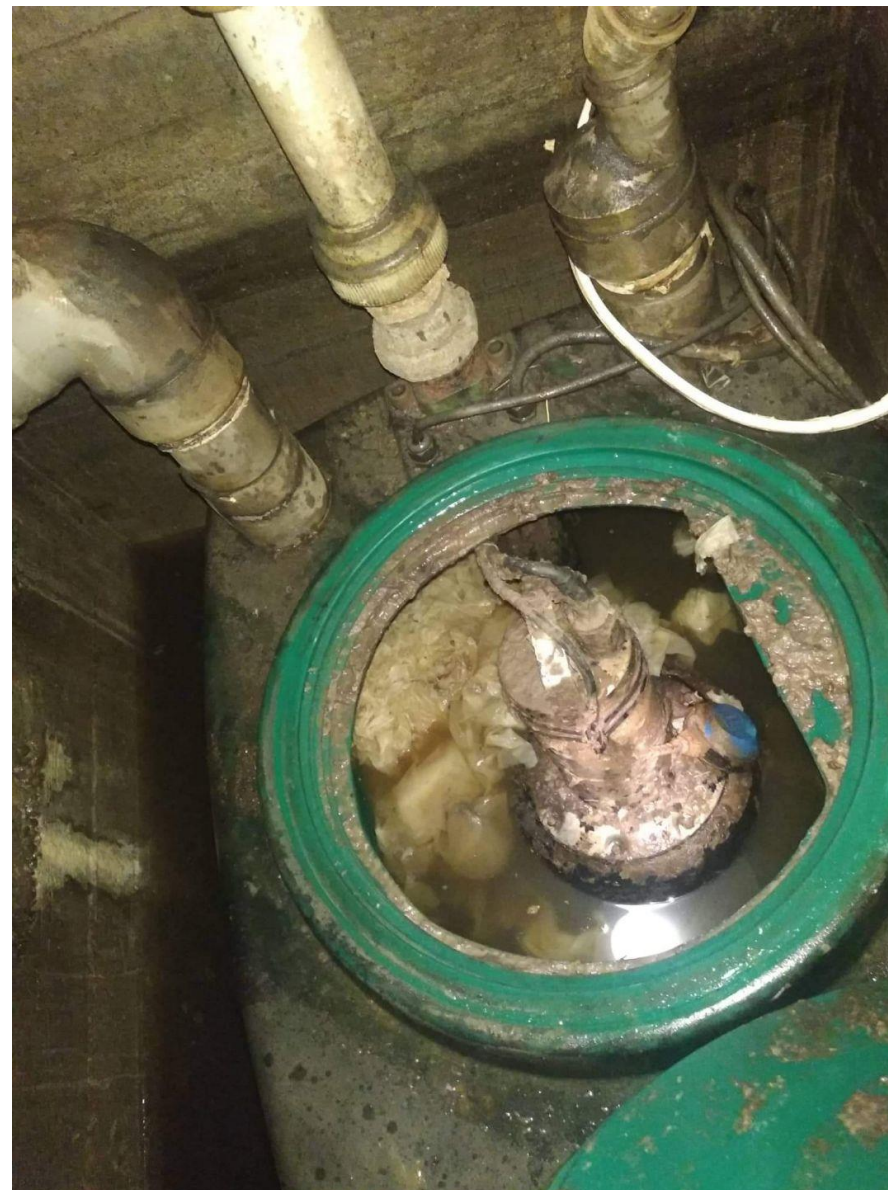



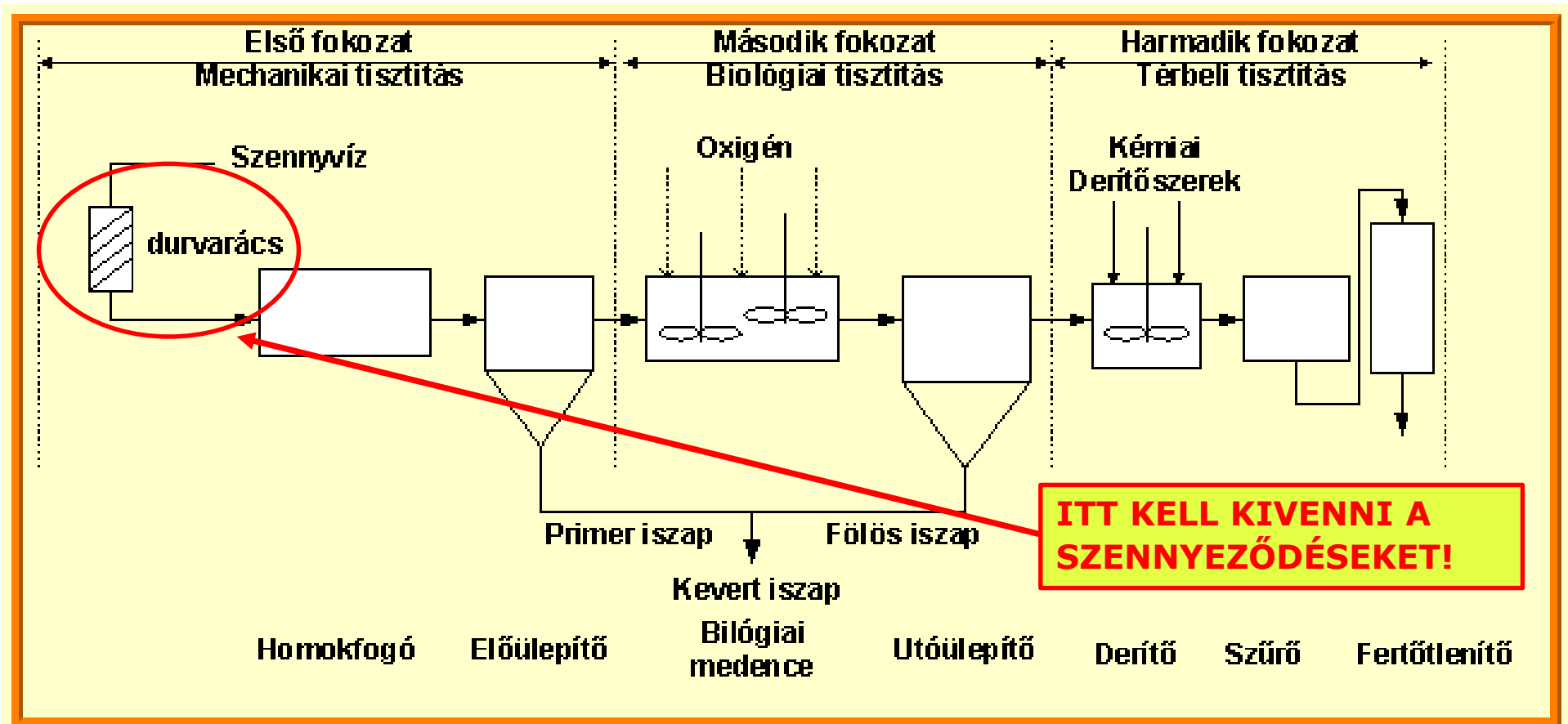

A szennyvíztisztítás általános folyamatábrája

Forrás: http://kemtech.net/tkurzus/06_viz/06main.htm#09

Szennyvíz átemelő élettartam költség eloszlása 15 év alatt

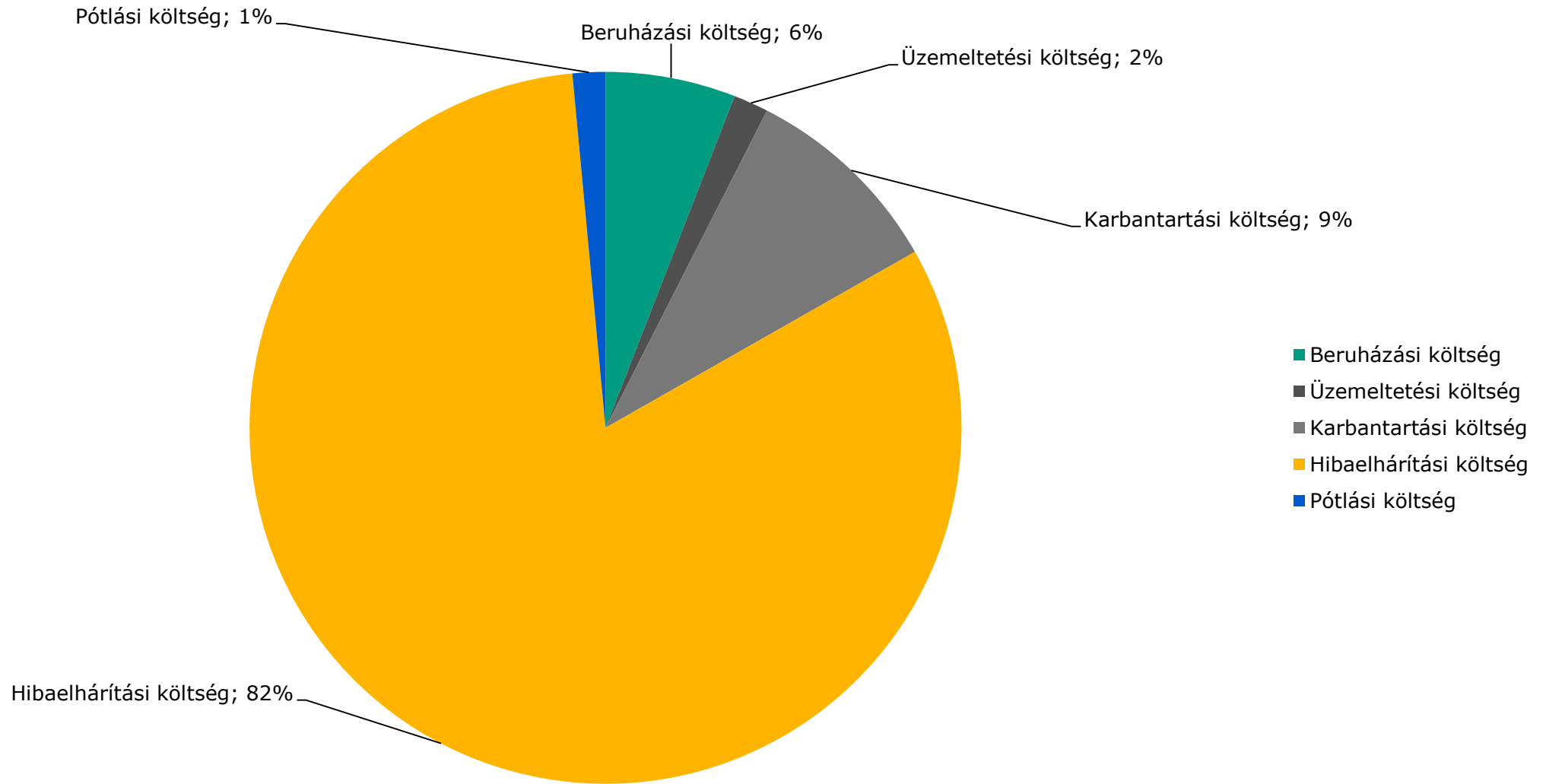

Hagyományos átemelő problémája

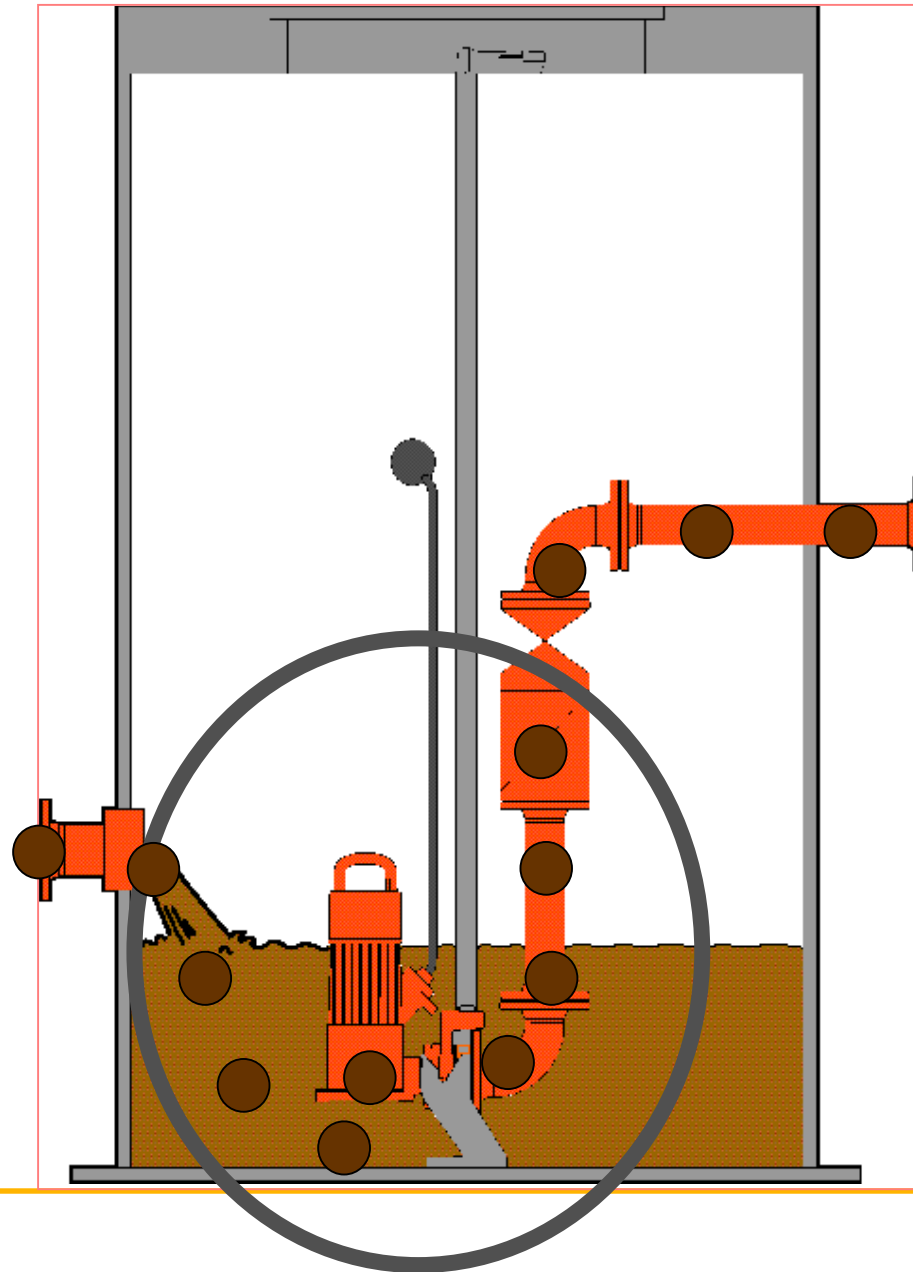

Hagyományos és szilárdanyag leválasztó rendszer

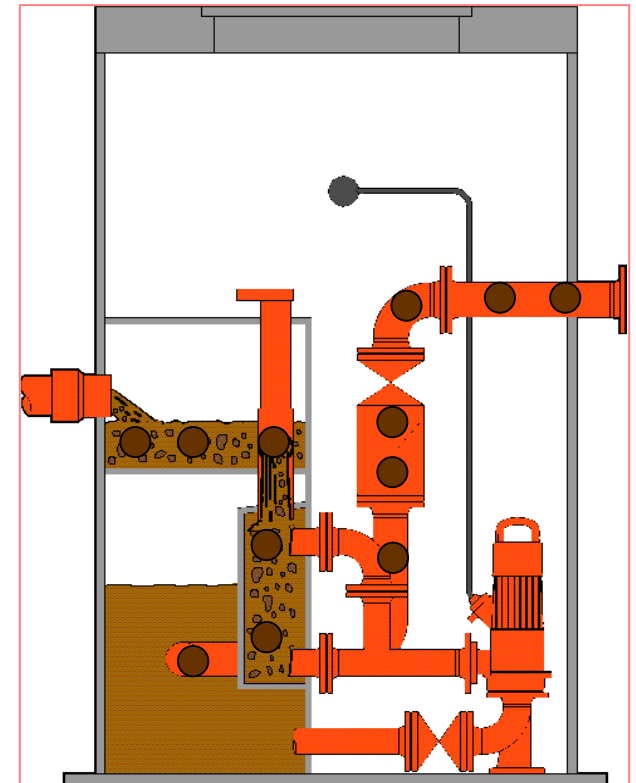
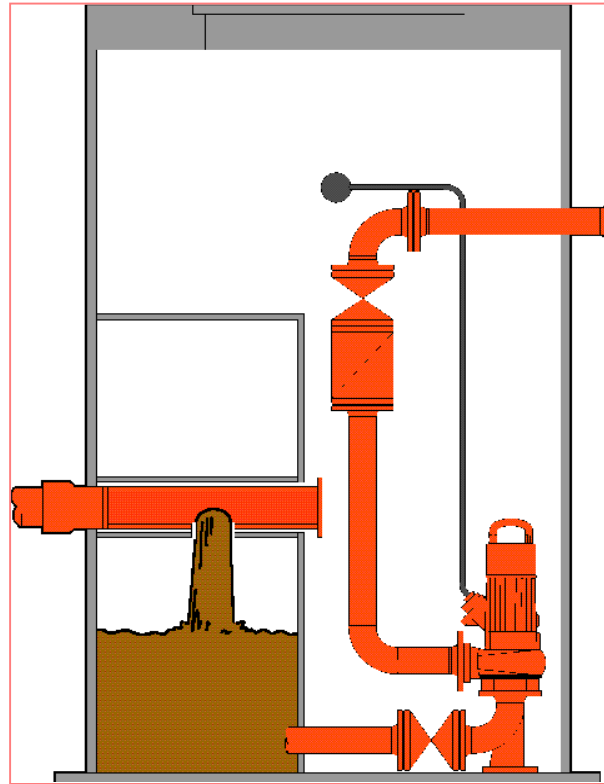
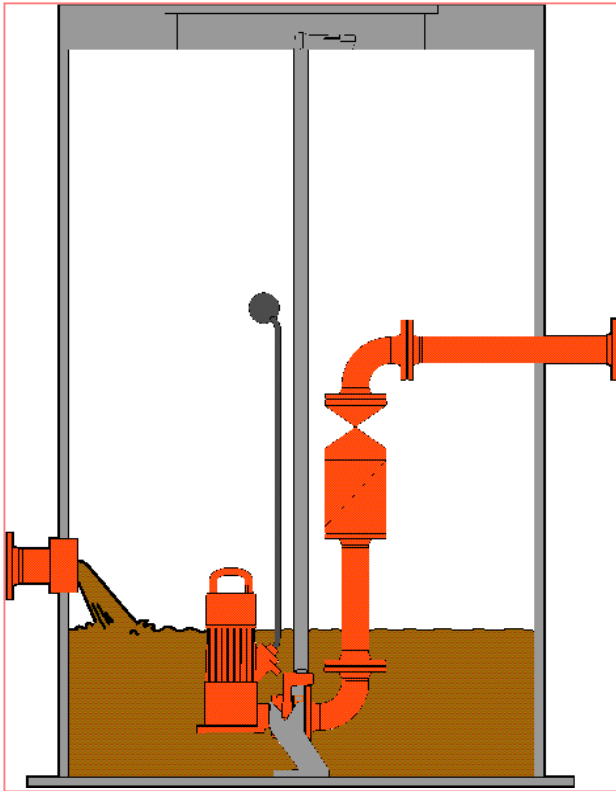

Wilo EMUport, dugulásmentes átemelő *wilo*

Van-e kérdés?



**Elérhetőség: a szakmai napon a Wilo asztalnál
vagy**

+36 70 932 5380, viktor.katus@wilo.com

Köszönöm a figyelmet!