

# Controlling solarthermal systems

---

Solar Energy Utilization in Building Technics  
Budapest, 08. November 2012

# Basic functions of solarthermal controllers

---

- Temperature differential control
- Control safety limits
- Storage priority
- Loading strategy
- Temperature sensors
- Position of the temperature sensors

# Preprogrammed solarthermal systems

---

- Easy to select the hydraulic system
- Most popular systems should be preprogrammed
- Allows the universal use of the controller

# Preprogrammed solarthermal systems

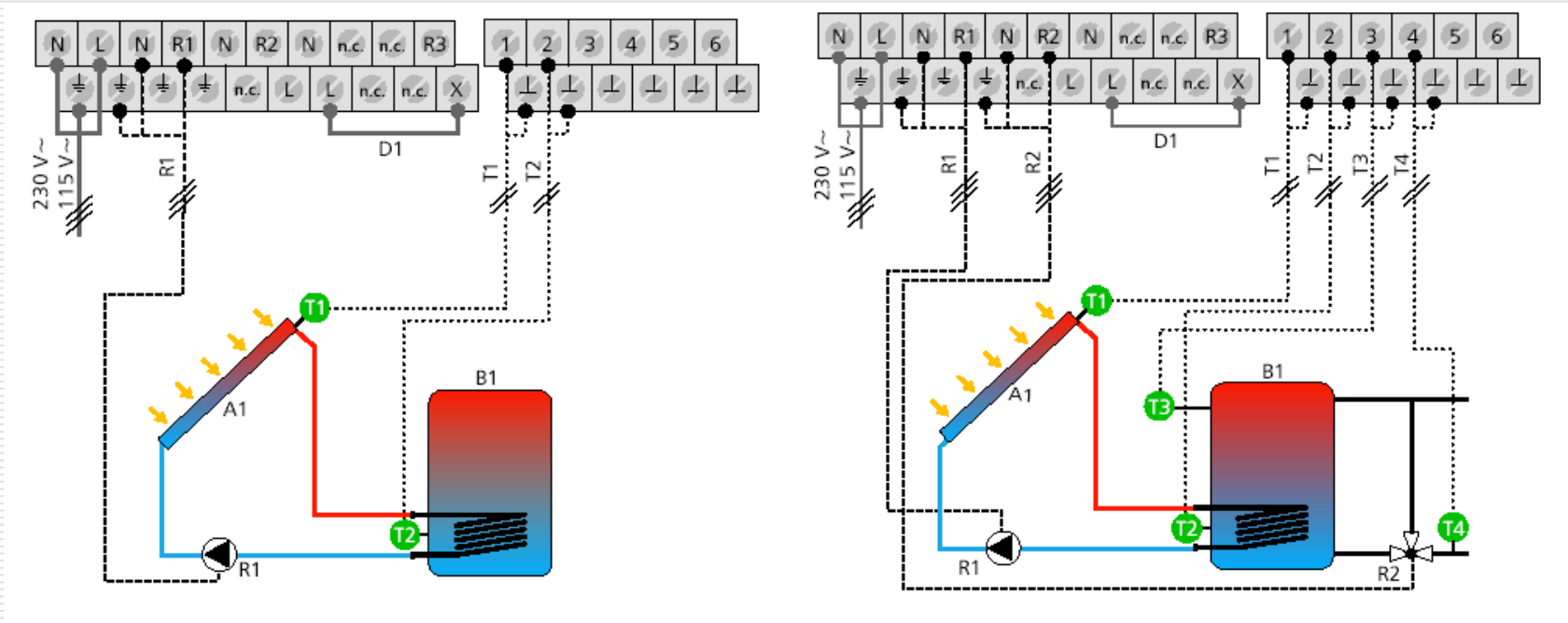

# Preprogrammed solarthermal systems

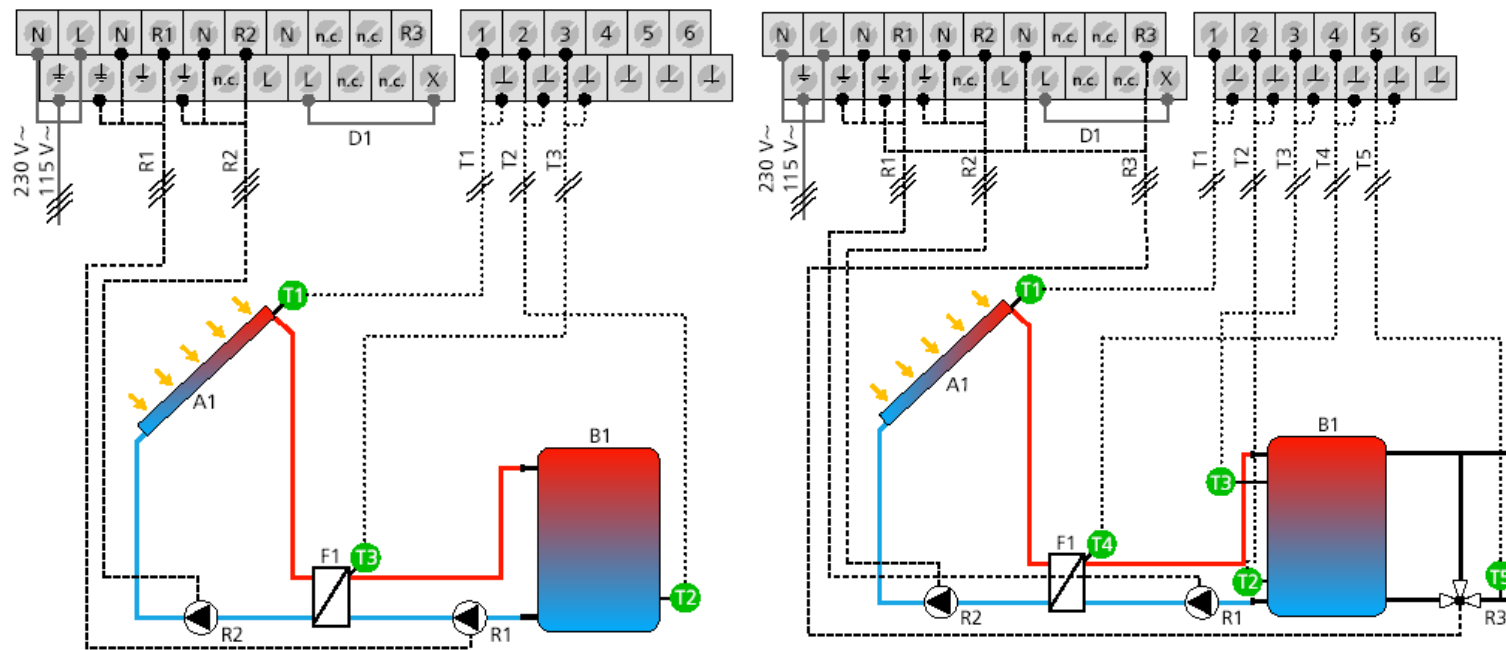

Budapest 08.11.2012

# Preprogrammed solarthermal systems

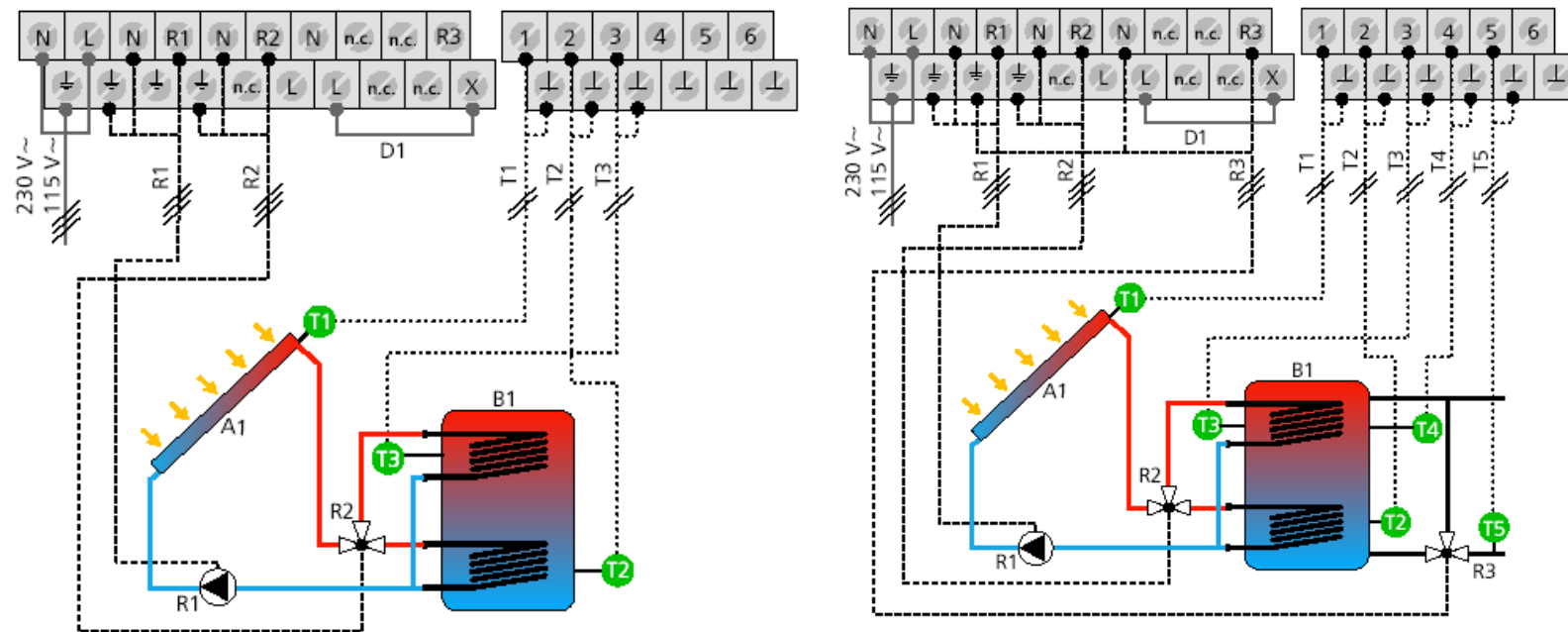

# Preprogrammed solarthermal systems

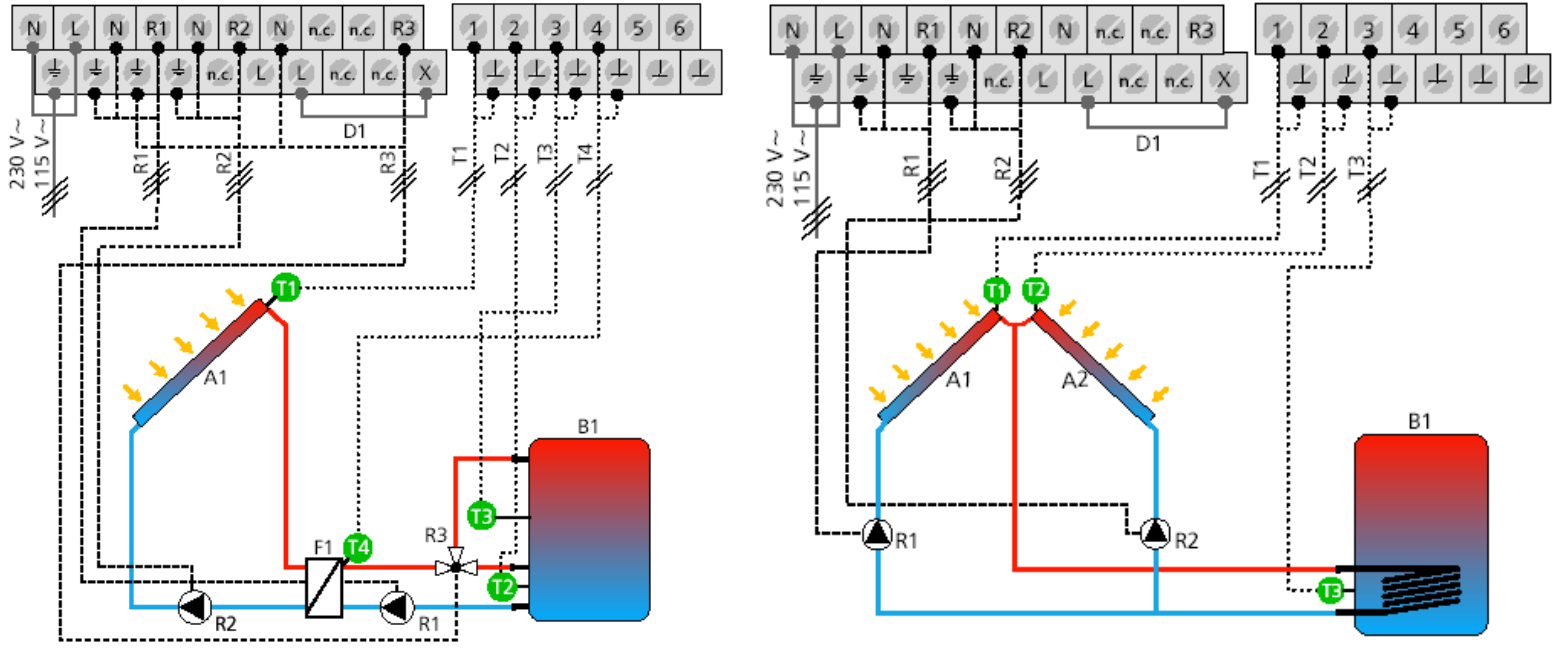

# Preprogrammed solarthermal systems

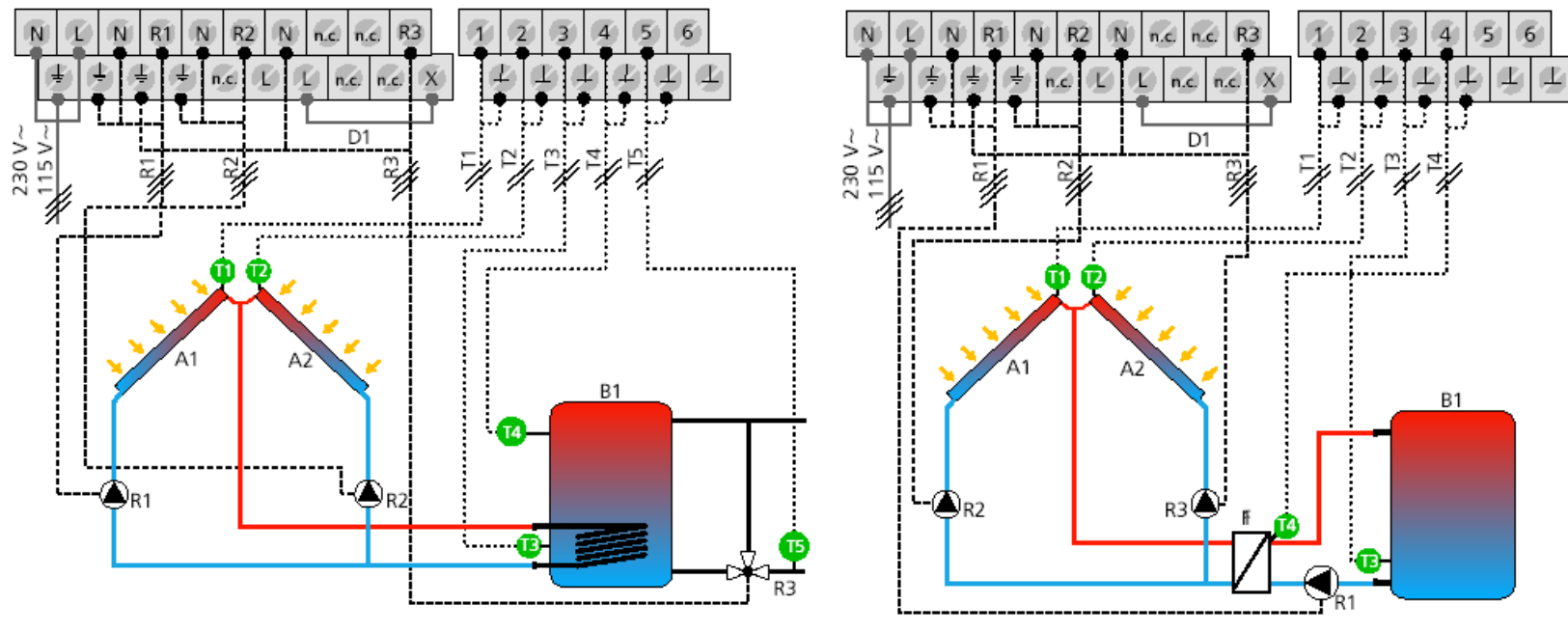

Budapest 08.11.2012



# Preprogrammed solarthermal systems

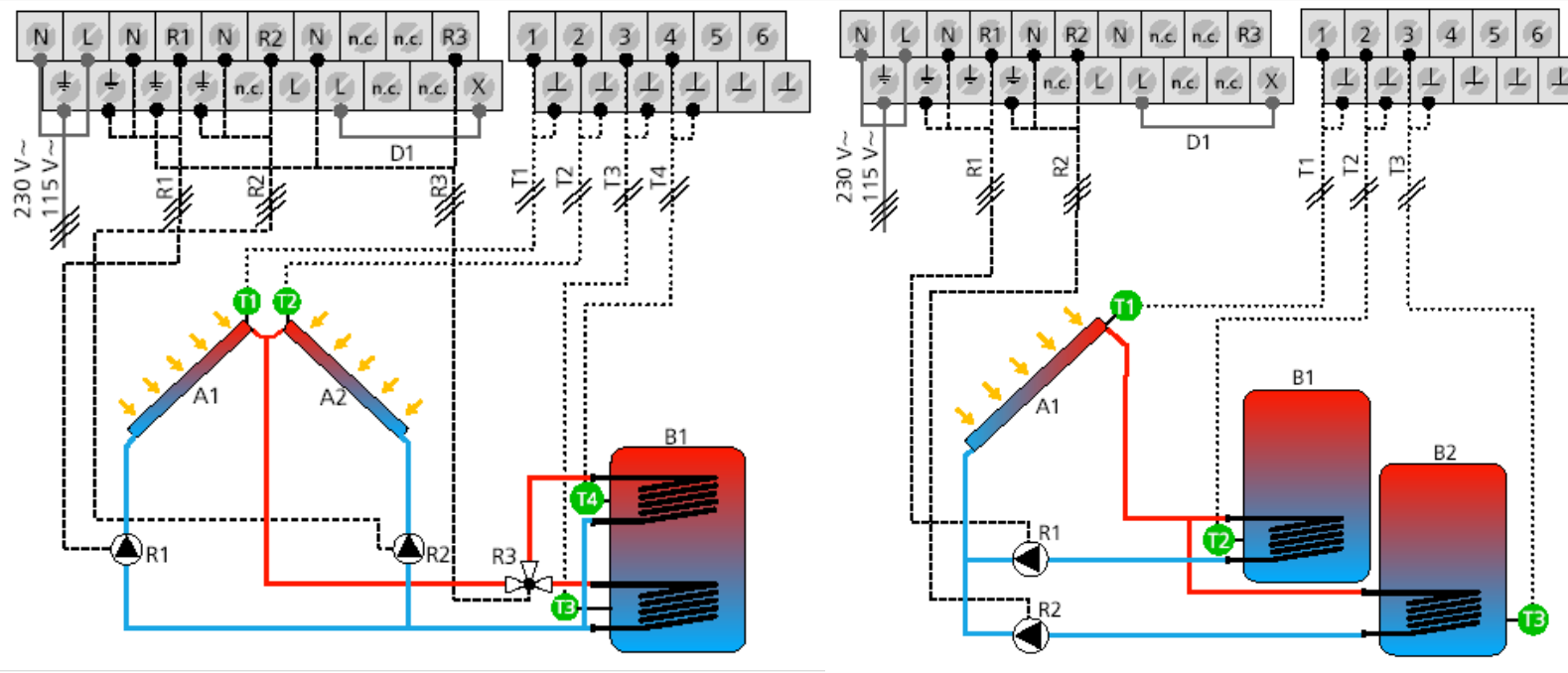

# Preprogrammed solarthermal systems

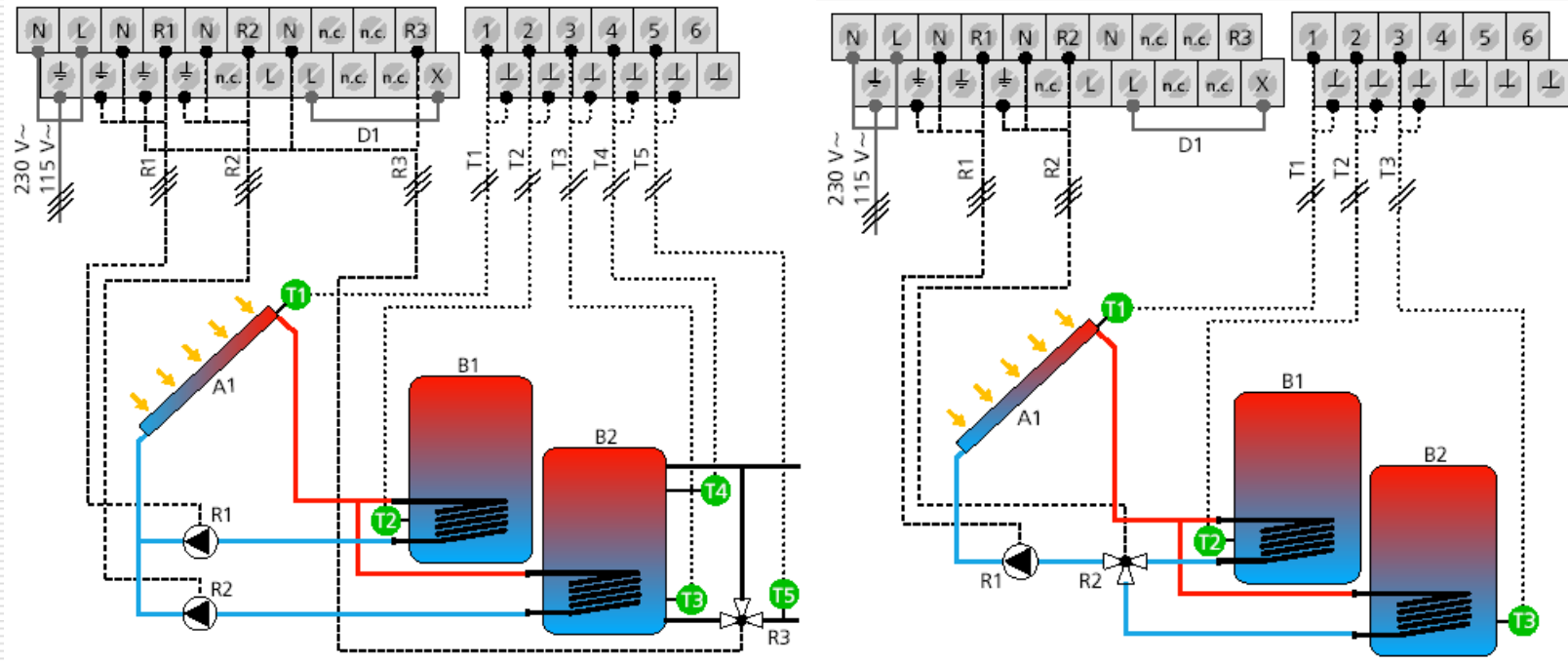

Budapest 08.11.2012

# Preprogrammed solarthermal systems

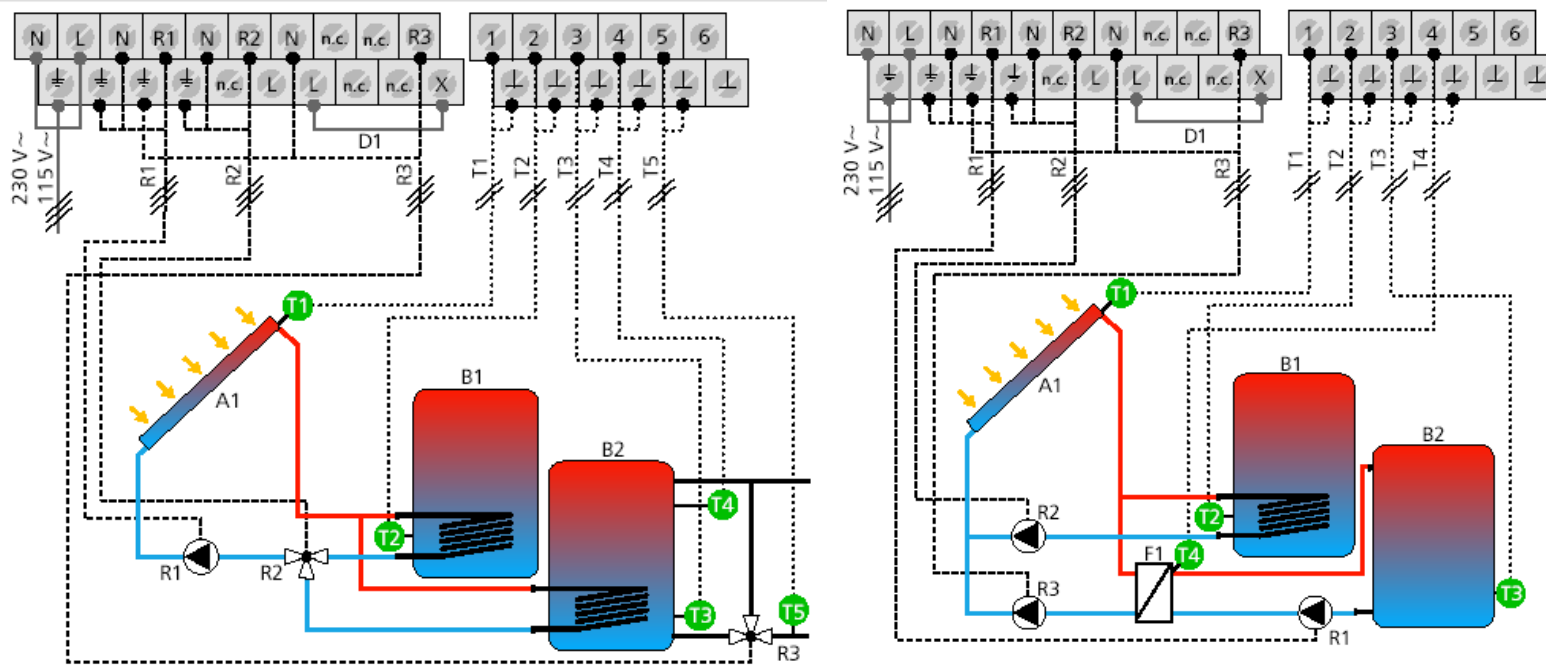

# Preprogrammed solarthermal systems

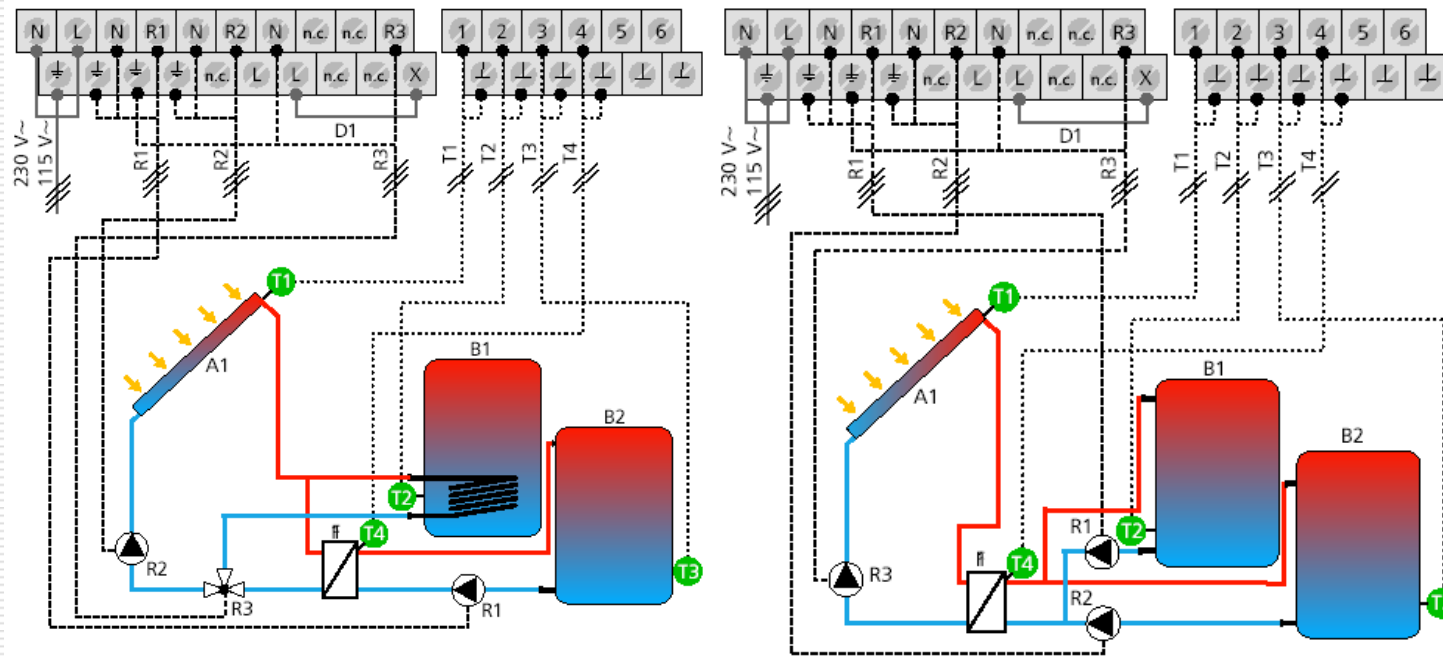

Budapest 08.11.2012

# Preprogrammed solarthermal systems

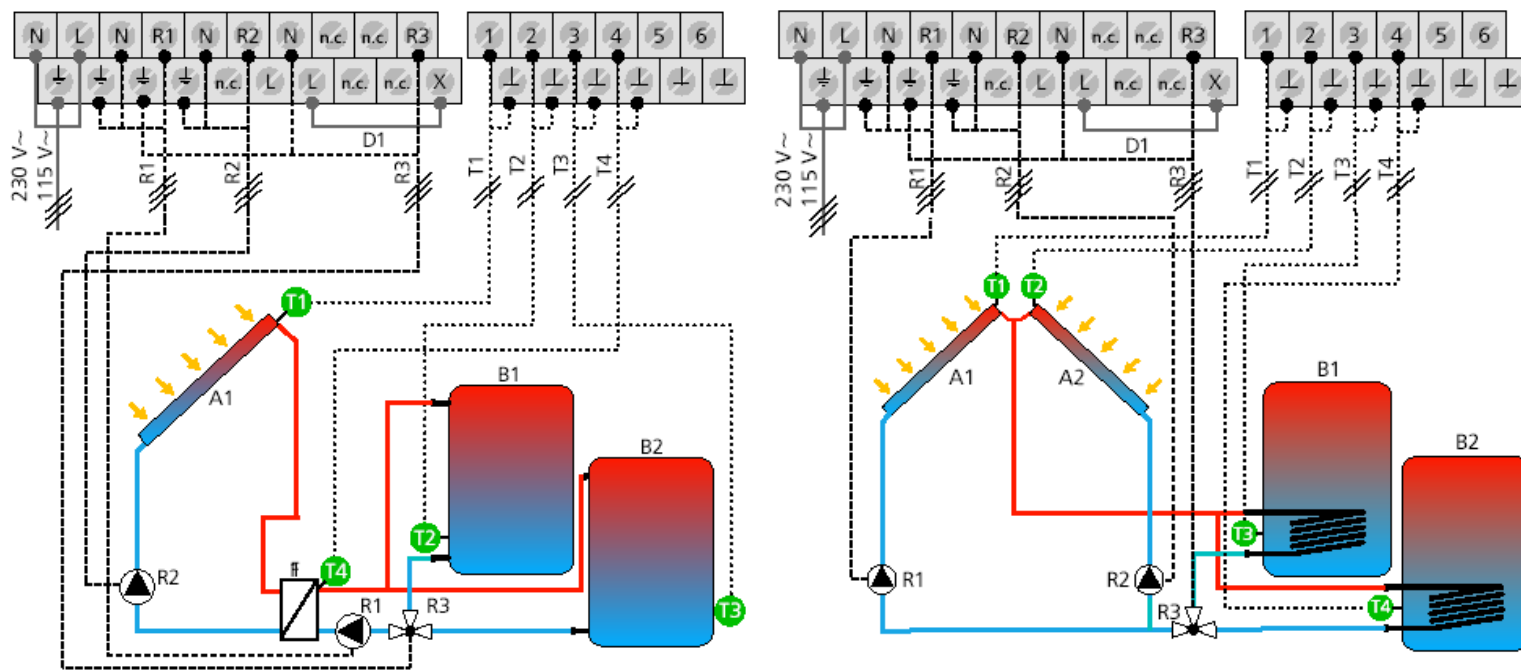

Budapest 08.11.2012

# Preprogrammed solarthermal systems

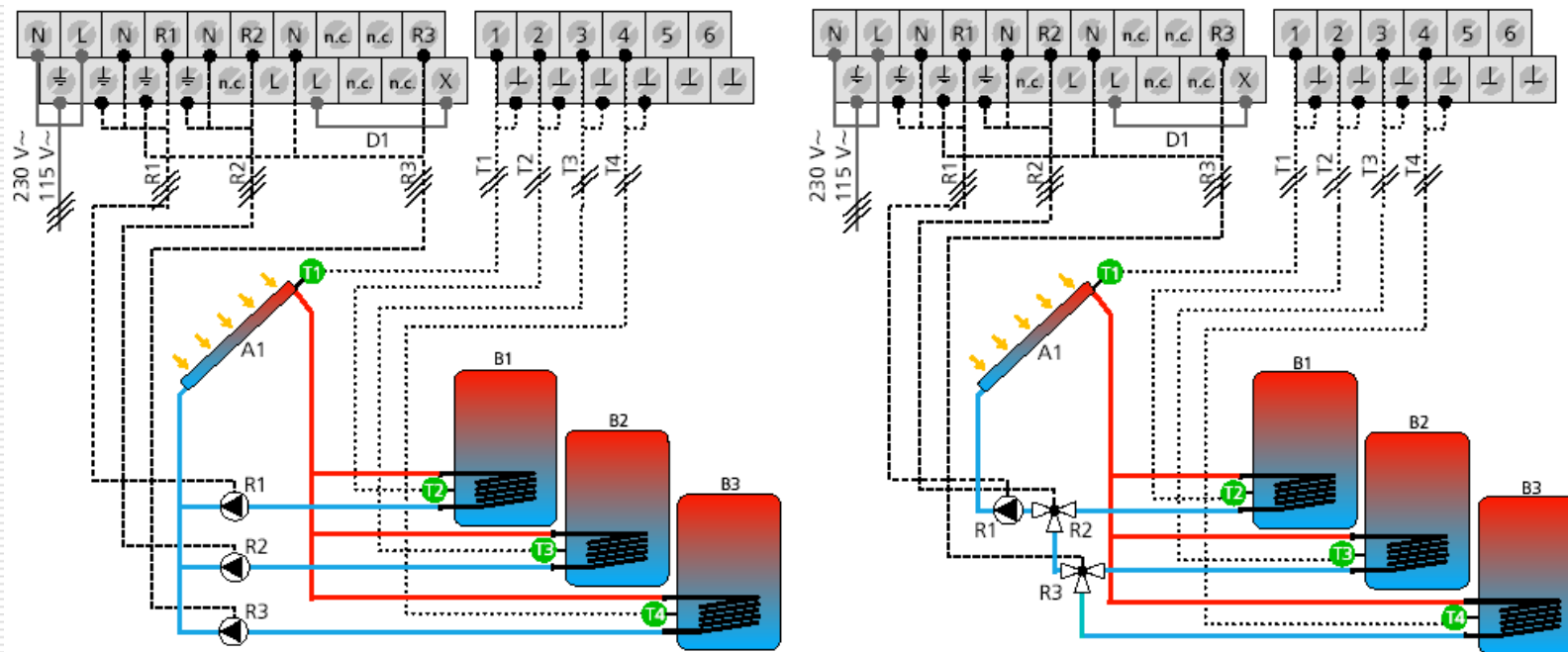

Budapest 08.11.2012

# Preprogrammed solarthermal systems

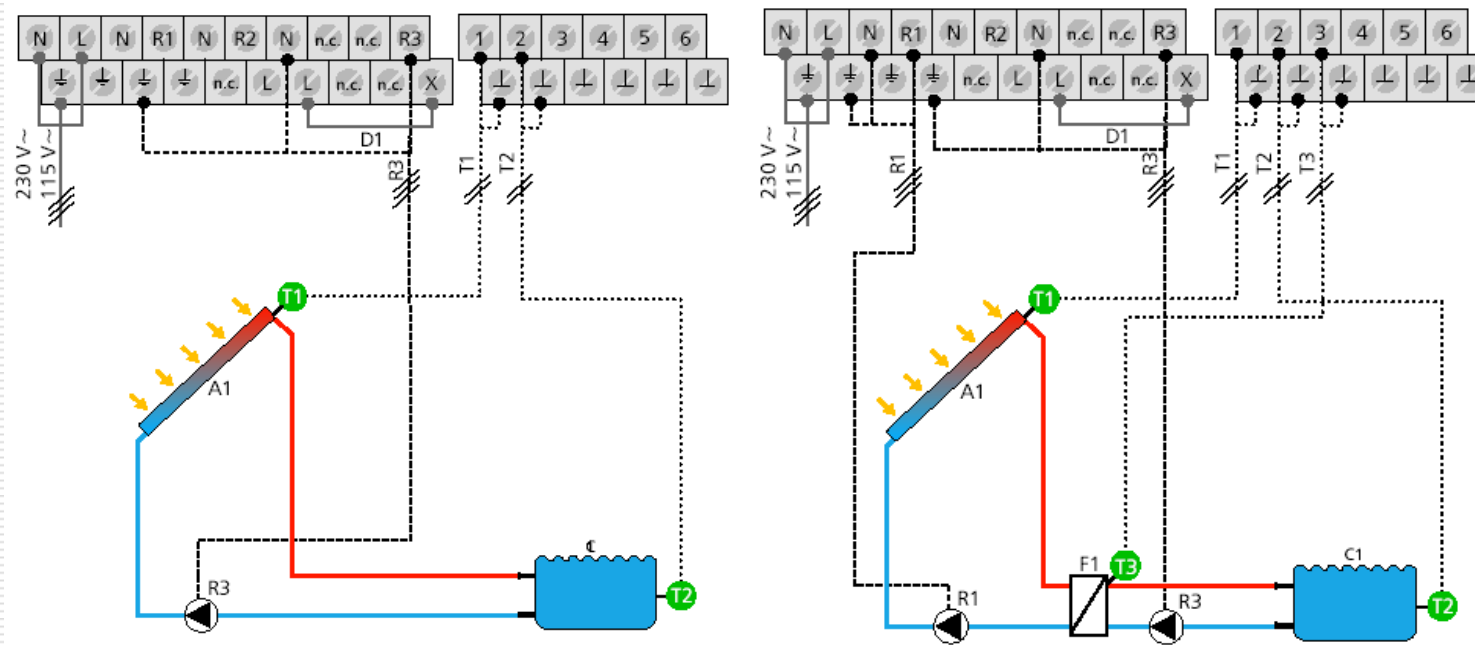

# Preprogrammed solarthermal systems

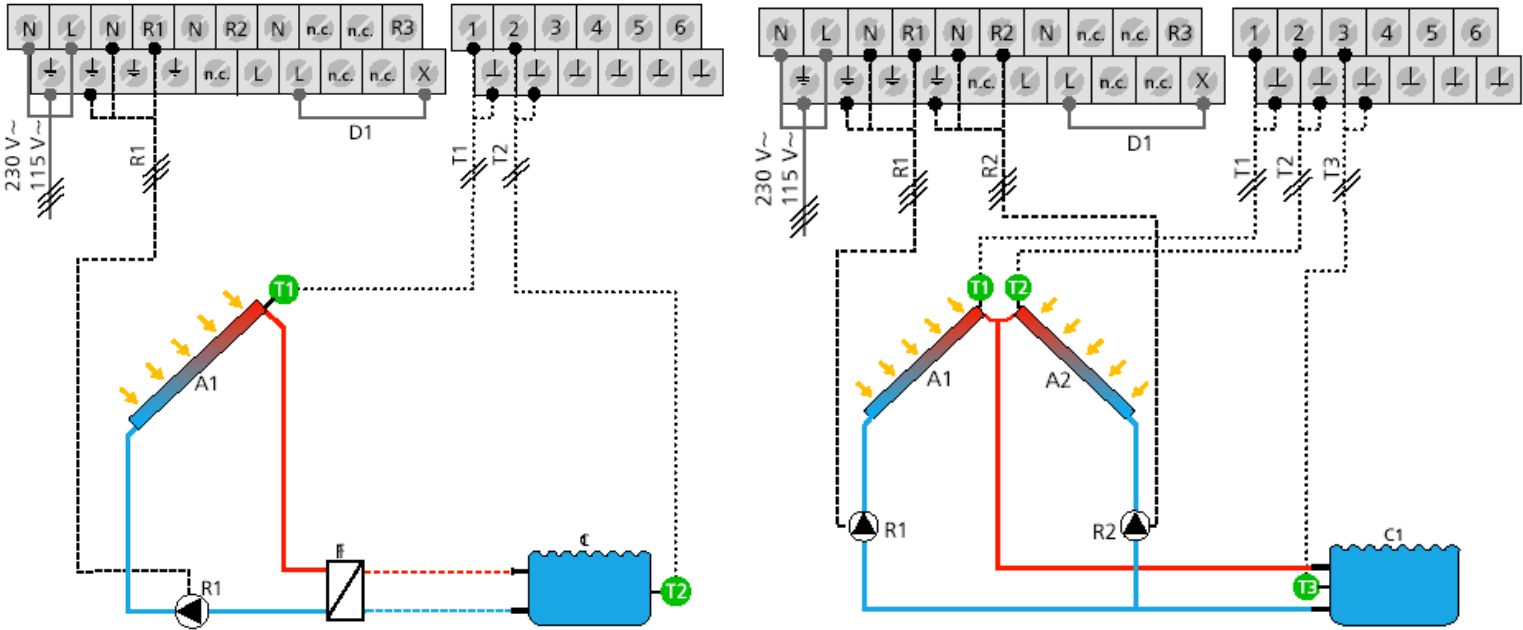



# Preprogrammed solarthermal systems

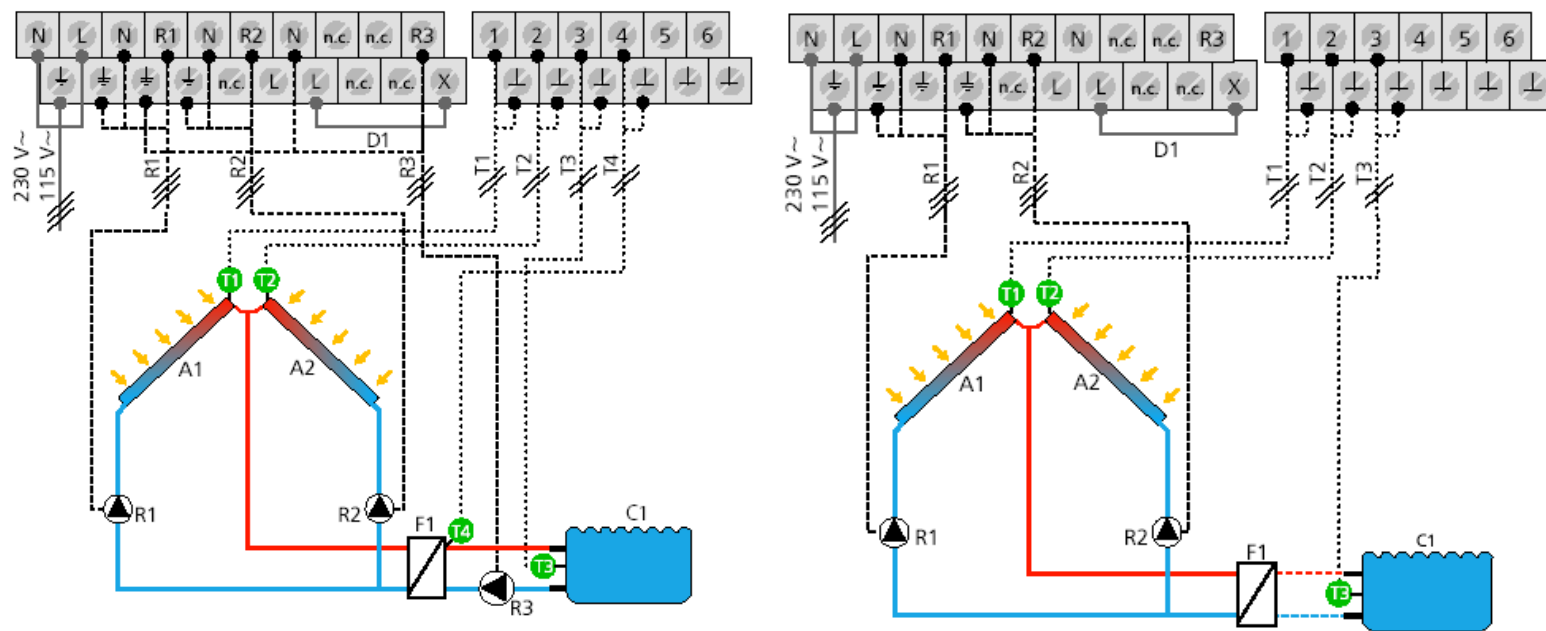

# Preprogrammed solarthermal systems

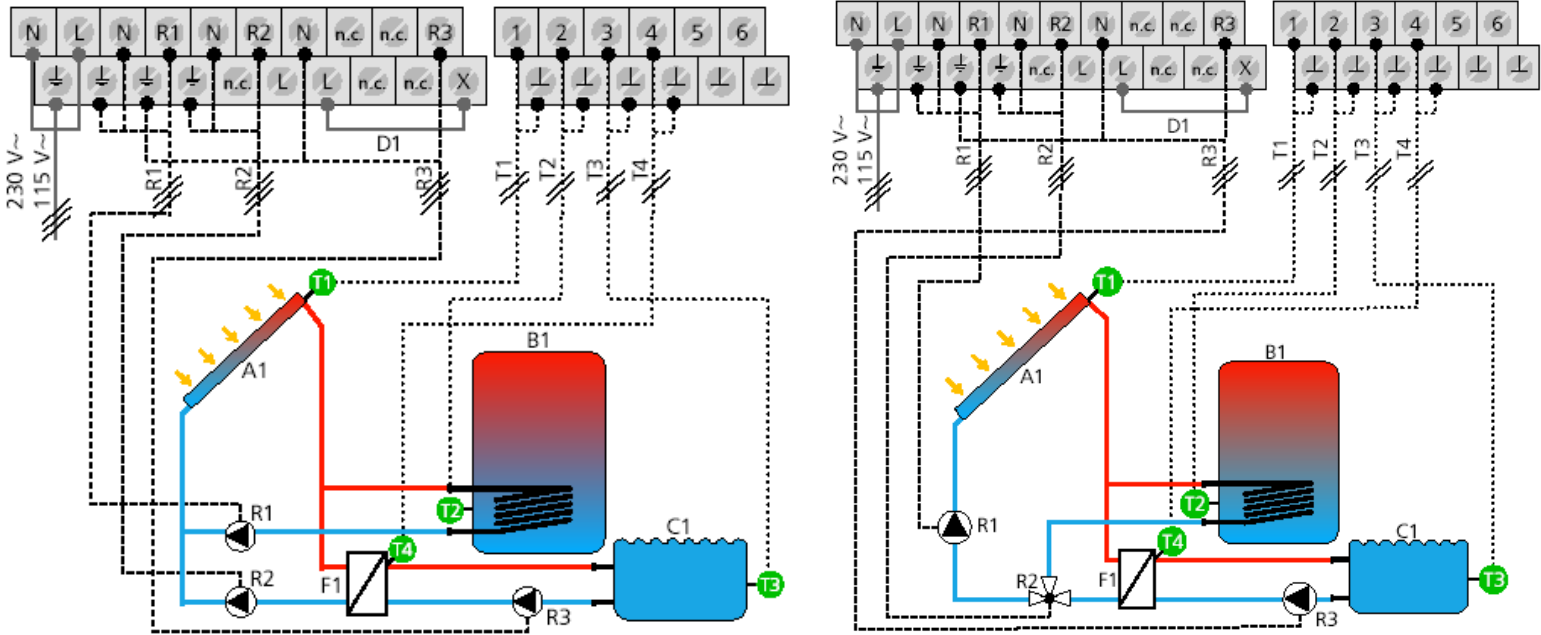

# Preprogrammed solarthermal systems

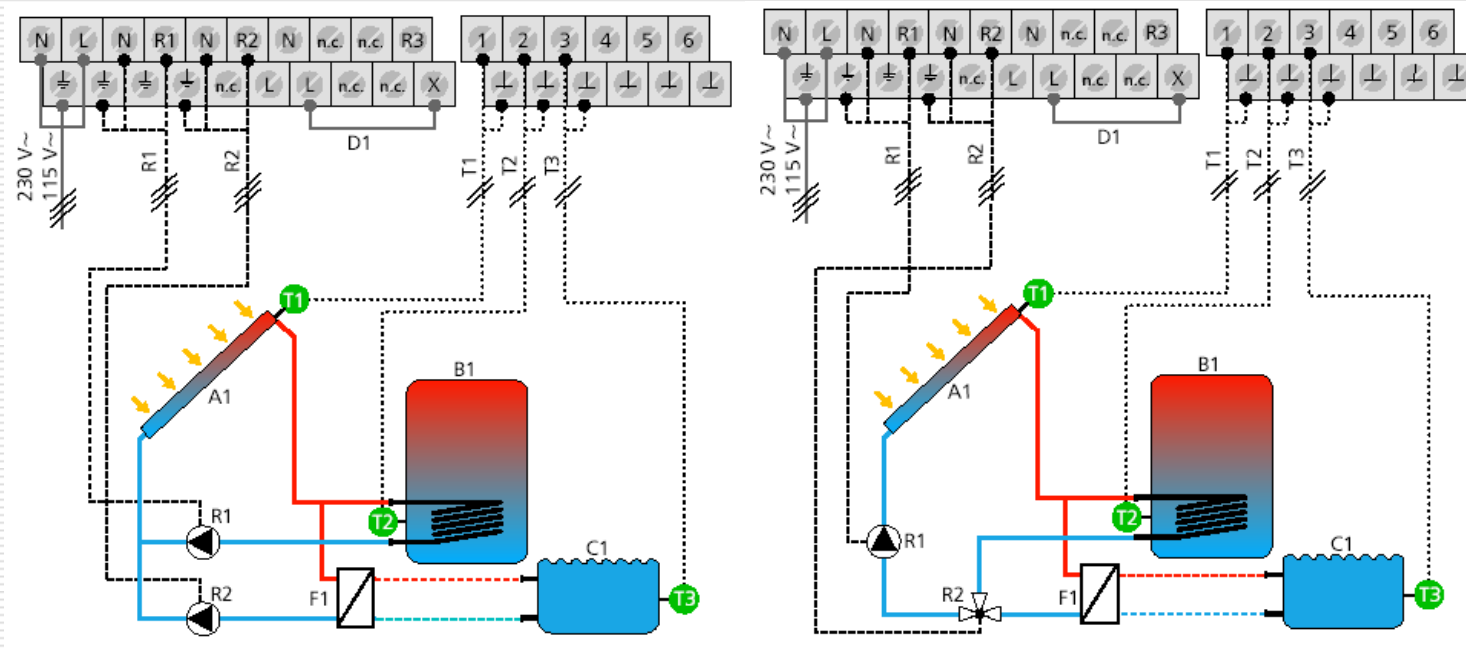

Budapest 08.11.2012

# Preprogrammed solarthermal systems

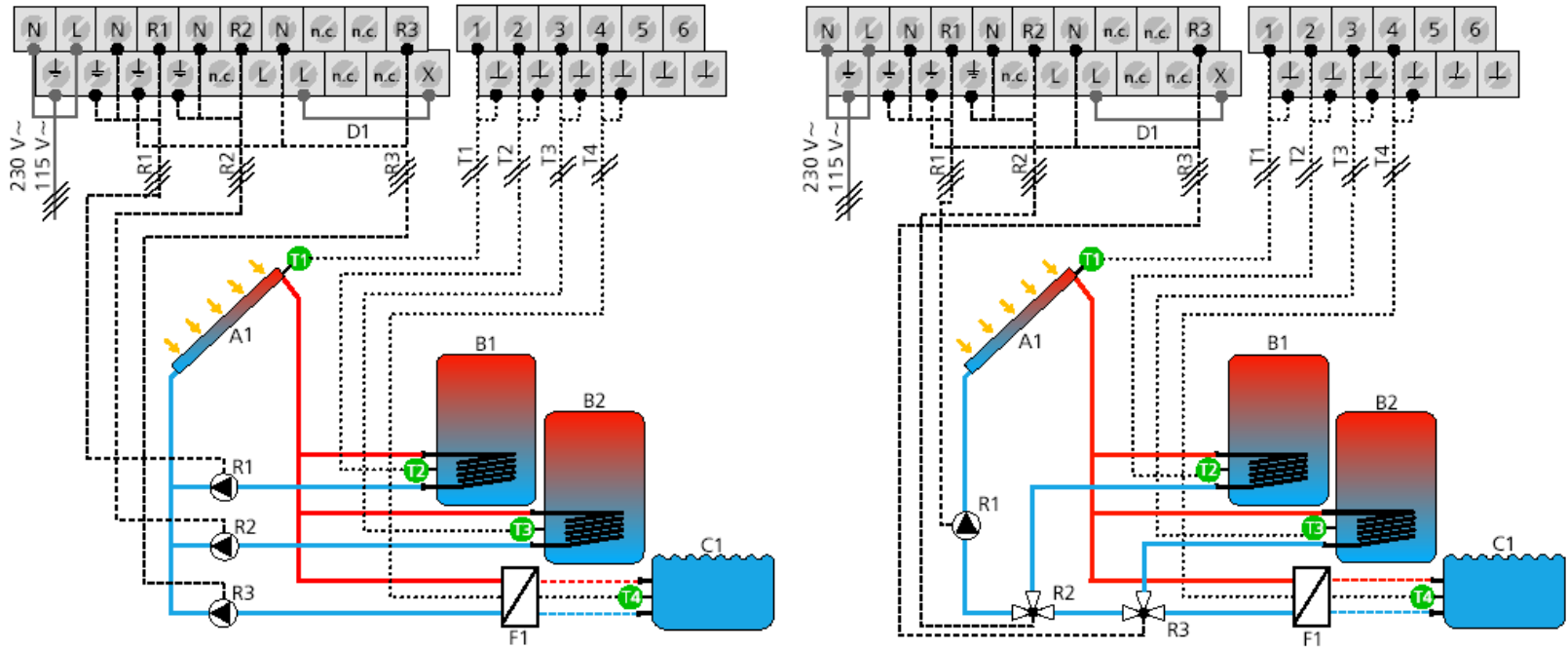

# Advanced functions

---

- Circulation
- Back-up heating
- Solid fuel boiler
- Quick charge
- Bypass
- Heat quantity
- Thermostat
- Difference thermostat
- Time function
- Display storage tank top temperature

# Special functions

---

- Interval
- Stagnation reduction
- Holiday function / recooling
- Frost protection
- Data logger
- Alarm output

# Special functions

---

- Stagnation reduction

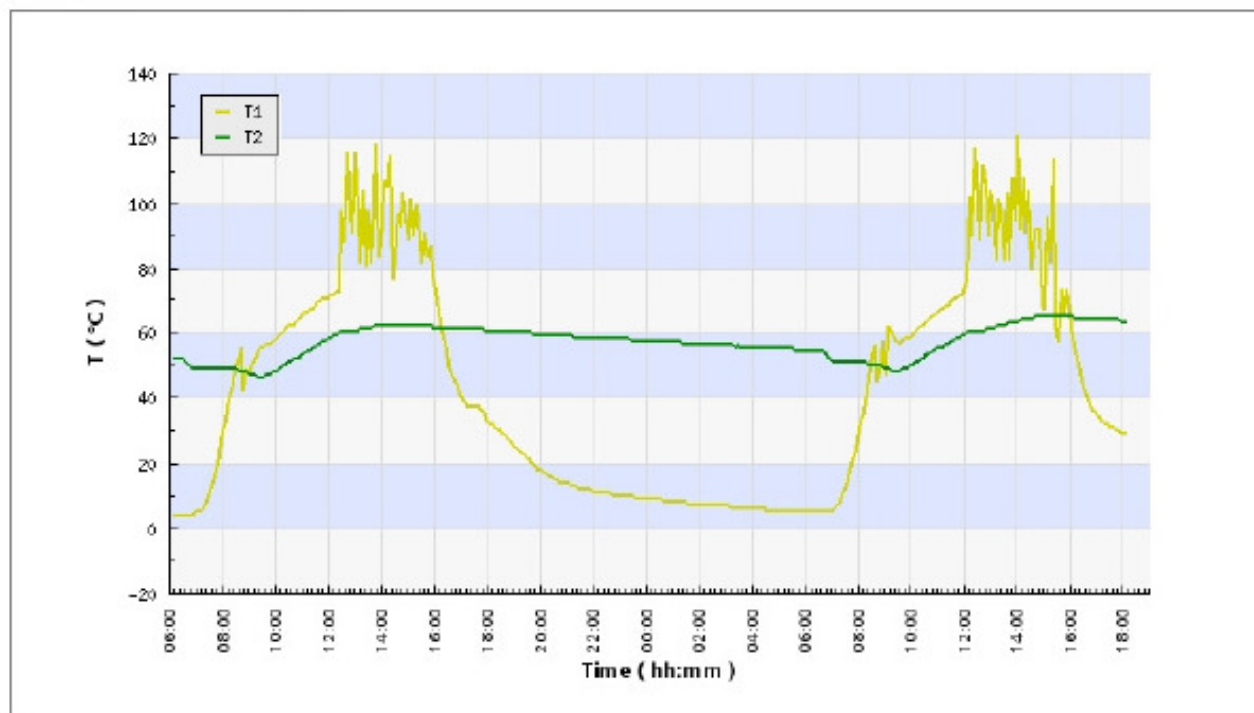

# Data logging and system analysis

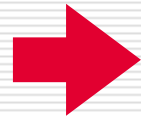

data evaluation

Software

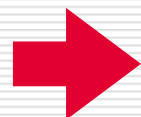
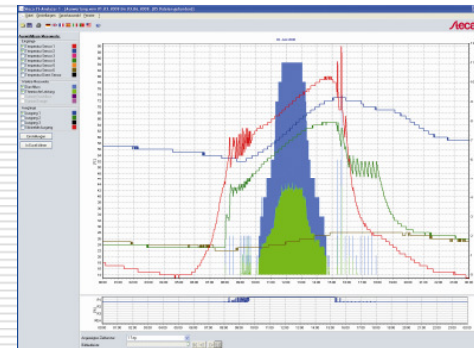

standard spreadsheet program (example „Excel“)

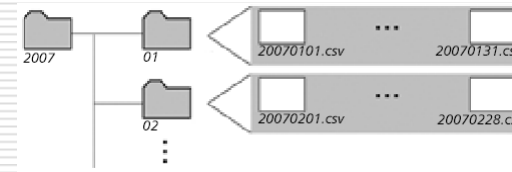

CSV data file

dd.mm.yy hh:mm	T1[C]	T2[C]	T3[C]	T4[C]	T5[C]	T6[C]	Tds[C]	V[l/min]	P[W]	R1[%]	R2[%]	R3[%]	Rl[%]
14.12.2007 00:00	70	166	90	71	32	29				0	0	0	0
14.12.2007 00:01	69	167	89	69	32	29				0	0	0	0
14.12.2007 00:02	69	167	89	50	32	29				93	93	93	0
14.12.2007 00:03	68	168	89	43	32	29				100	100	100	0
14.12.2007 00:04	68	170	89	39	32	29				100	100	100	0
14.12.2007 00:05	68	173	89	36	32	29				100	100	100	0



# Data logging and system analysis

## Analyzing Software

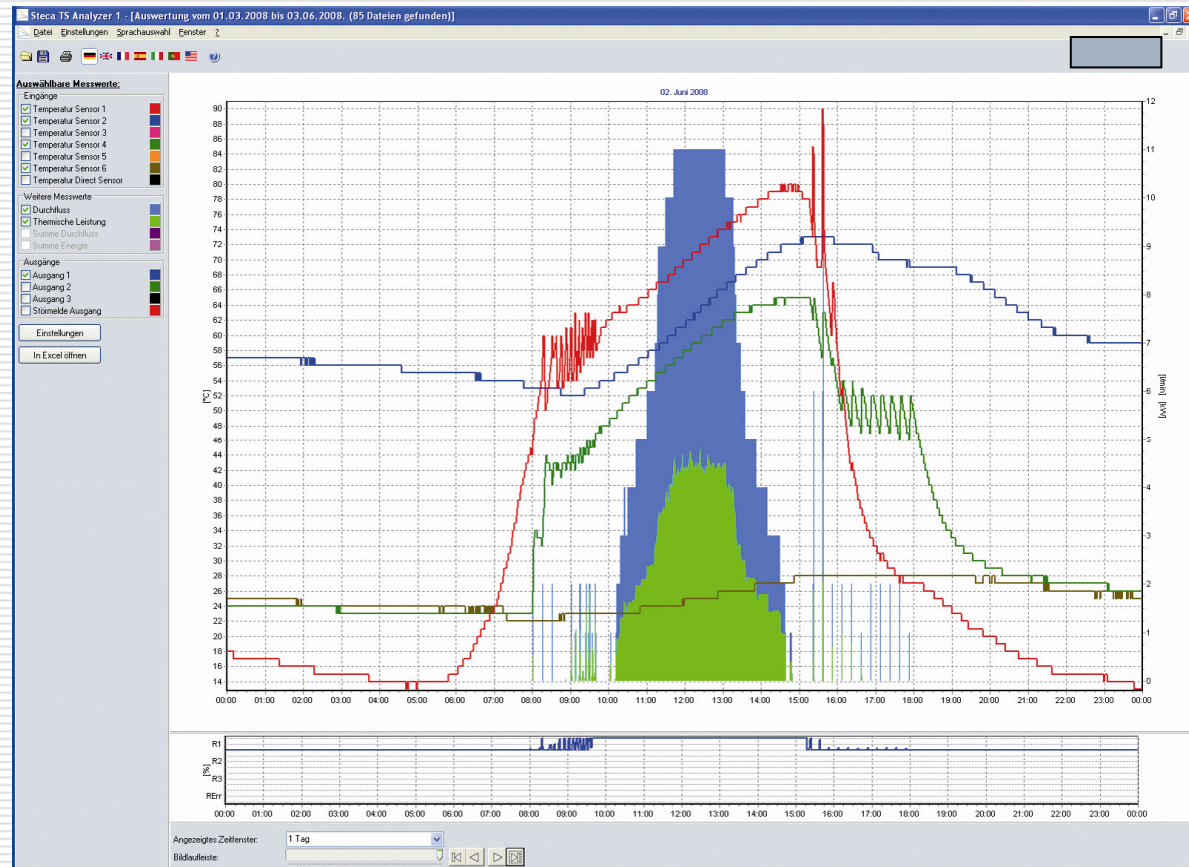

Budapest 08.11.2012

# Monitoring and control functions

---

- A Internet remot display allows permanent monitoring and performance analysis of one or more solar energy systems

# Monitoring and control functions

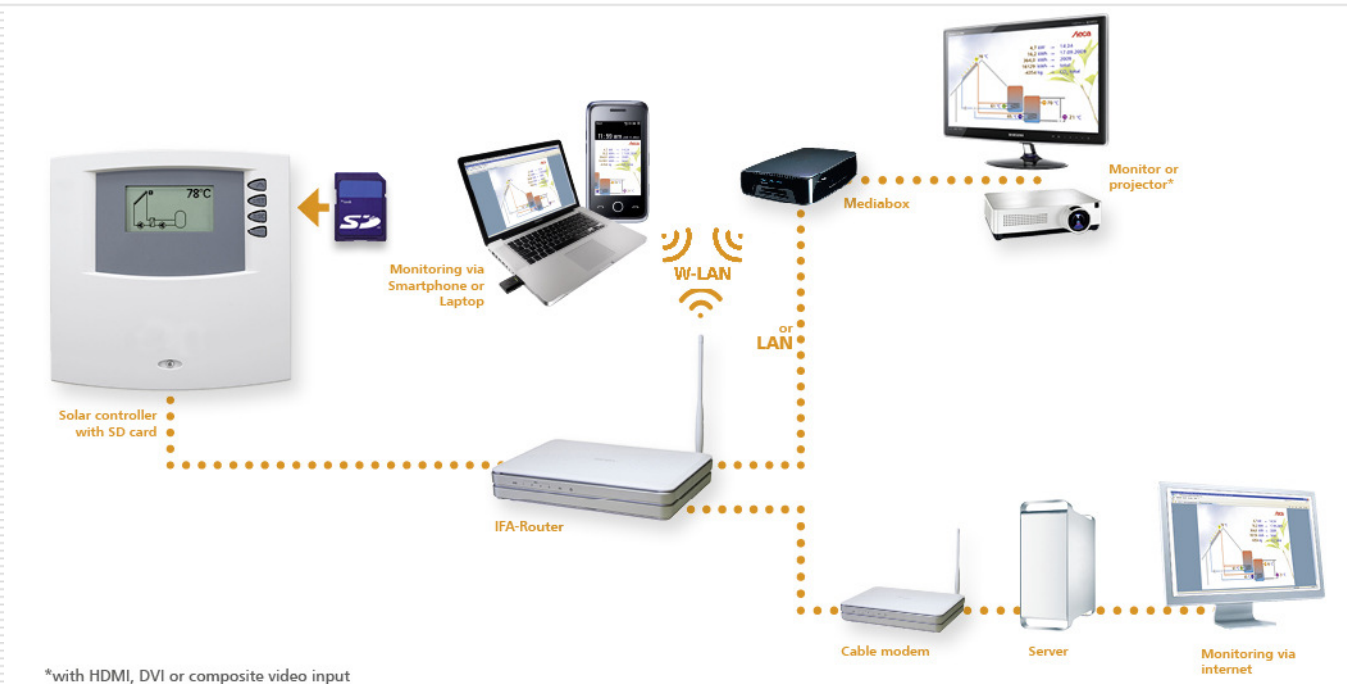

Budapest 08.11.2012

# Monitoring and control functions

---



Budapest 08.11.2012

## Useful accessories

---

- Overvoltage protection



- Pt1000 Temperature sensor



# Useful accessories

---

## □ Flowmeter



$Q_N = 1,5 \text{ m}^3/\text{h}$   
Pulse rate: 1 l/Impuls

---

Thank you very much for your attention